



## SPECIFICATIONS FOR LCD MODULE

<b>CUSTOMER</b>	
<b>CUSTOMER PART NO.</b>	
<b>AMPIRE PART NO.</b>	<b>AC-402A</b>
<b>APPROVED BY</b>	
<b>DATE</b>	

**AMPIRE CO., LTD.**

**TOWER A, 4F, No.114, Sec. 1, HSIN-TAI 5th RD., HIS-CHIH,  
TAIPEI HSIEN, TAIWAN(R.O.C.)**

**台北縣汐止鎮新台五路一段114號4樓(東方科學園區A棟)**

**TEL:886-2-26967269, FAX:886-2-26967196 or 886-2-26967270**

<b>APPROVED BY</b>	<b>CHECKED BY</b>	<b>ORGANIZED BY</b>

## RECORD OF REVISION

Revision Date	Page	Contents
1999/9/1	-	New Release
2000/10/6	14	Modify sampling plan
2001/12/12		Modify LED characteristic
2007/2/7	6	Modify EL Back-light Characteristics

## 1 FEATURES

- (1) Display format : 40 characters × 2 lines
- (2) Construction : STN LCD, Bezel, Zebra and PCB.
- (3) Optional LED or EL back-light.
- (4) Controller : KS0066U or Equivalent.
- (5) 5V single power input. (Special request for 3.3V driving, built-in DC/DC converter.)
- (6) Normal / Extended temperature type.
- (7) Excellent LC : VOP maintains at 5V for whole temp. range, no need extra temp. compensation circuit.

## 2 NUMBERING SYSTEM

**AC-402A** \_ \_ \_ \_ - \_  
           **1 2 3 4 5**

No	Code Value	Description	Remark
1	G	STN gray type LCD	LCD Type
	Y	STN yellow green type LCD	
	S	STN negative type LCD	
2	A	Reflective type / 6:00 view	Polarizer / Viewing Angel
	B	Reflective type / 12:00 view	
	I	Transflective type / 6:00 view	
	J	Transflective type / 12:00 view	
	T	Negative type / 6:00 view	
	U	Negative type / 12:00 view	
3	None	Without backlight	Backlight type
	L	5V LED	
	E	EL	
4	None	Without backlight	Backlight color
	Y	Yellow-green (LED)	
	B	Blue (EL)	
	W	White (EL)	
5	None	Normal temperature type	LCM temperature type
	H	Extended temperature type	

### 3 MECHANICAL DATA

Parameter	Stand Value	Unit
Dot size	0.60(W) × 0.65(H)	mm
Dot pitch	0.65(W) × 0.70(H)	mm
Character size	3.20(W) × 5.55(H)	mm
Viewing area	154.0(W) × 16.5(H)	mm
Module size	182.0(W) × 33.5(H) × 10.5 max (T)	mm
Module size (w/ LED back-light)	182.0(W) × 33.5(H) × 14.0 max (T)	mm

### 4 ABSOLUTE MAXIMUM RATINGS

Parameter		Symbol	Min	Max	Unit
Logic Circuit Supply Voltage		VDD-VSS	-0.3	7.0	V
LCD Driving Voltage		VDD-VO	-0.3	10.0	V
Input Voltage		VI	-0.3	VDD+0.3	V
Normal temp. type	Operating Temp.	TOP	0	50	°C
	Storage Temp.	TSTG	-20	70	°C
Extended temp. type	Operating Temp.	TOP	-20	70	°C
	Storage Temp.	TSTG	-30	80	°C

## 5 ELECTRO-OPTICAL CHARACTERISTICS

Parameter	Symbol	Condition	Min	Typ	Max	Unit	Note
----- Electronic Characteristics -----							
Logic Circuit Supply Voltage	VDD-VSS	--	2.7	--	5.5	V	
LCD Driving Voltage	VDD-VO	-20 °C	4.75	5.0	5.25	V	0 ~ 50 °C for Normal Temp. type -20 ~ 70 °C for Extended Temp. type
		0 °C	4.75	5.0	5.25		
		25 °C	4.75	5.0	5.25		
		50 °C	4.75	5.0	5.25		
		70 °C	4.75	5.0	5.25		
Input Voltage	VIH	--	0.7 VDD	--	VDD	V	
	VIL	--	VSS	--	0.3 VDD	V	
Logic Supply Current	IDD	VDD = 5V	--	2.0	3.0	mA	
----- Optical Characteristics -----							
Contrast	CR	25°C	--	5	--		Note 1
Rise Time	tr	25°C	--	200	300	ms	Note 2
Fall Time	tf	25°C	--	200	300	ms	
Viewing Angle Range	θ f	25°C & CR≥2	--	40	--	Deg.	Note 3
	θ b		--	35	--		
	θ l		--	35	--		
	θ r		--	35	--		
Frame Frequency	fF	25°C	--	64	--	Hz	
----- LED Back-light Characteristics -----							
Forward Voltage	VF	--	--	4.05	4.3	V	Supply Voltage between A&K
Forward Current	IF	VF=4.05V	--	280	--	mA	
LCM Luminous intensity		VF=4.05V	--	30	--	cd/m <sup>2</sup>	

\* LED Dice number = 2×28=56

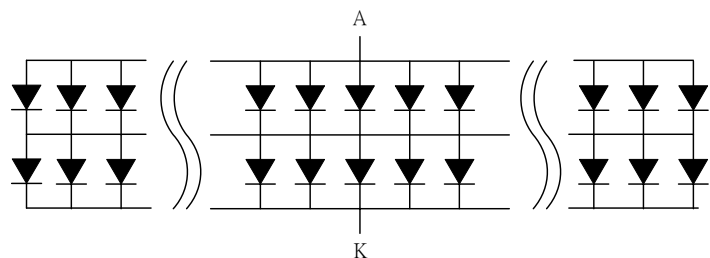

<b>----- EL Back-light Characteristics -----</b>					
<b>Parameter</b>	<b>Min</b>	<b>Typ</b>	<b>Max</b>	<b>Unit</b>	<b>Note</b>
Driving Voltage	--	110	--	Vrms	
Frequency	--	400	--	Hz	
LCM Luminous intensity	--	5	--	cd/m <sup>2</sup>	

(NOTE 1) Contrast ratio :

$$CR = (\text{Brightness in OFF state}) / (\text{Brightness in ON state})$$

(NOTE 2) Response time :

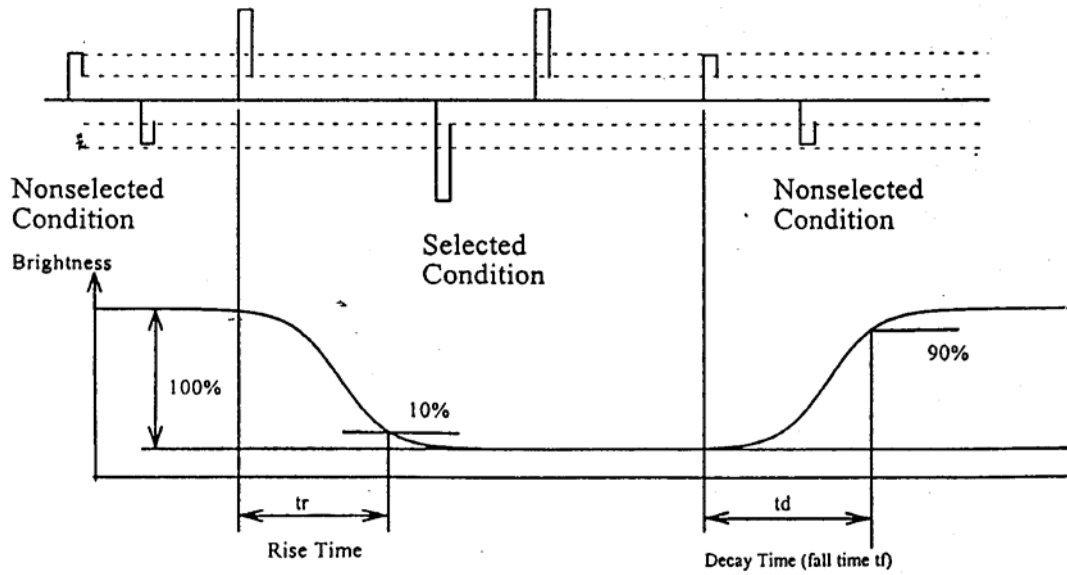

(NOTE 3) Viewing angle

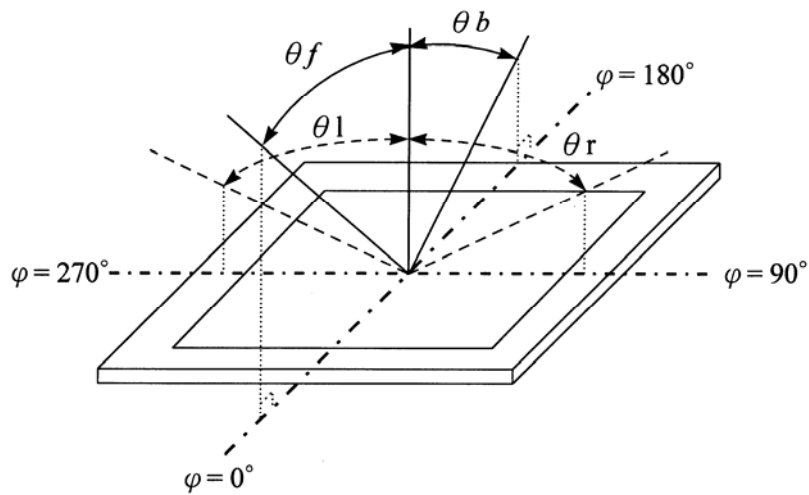

## 6 BLOCK DIAGRAM & INTERFACE

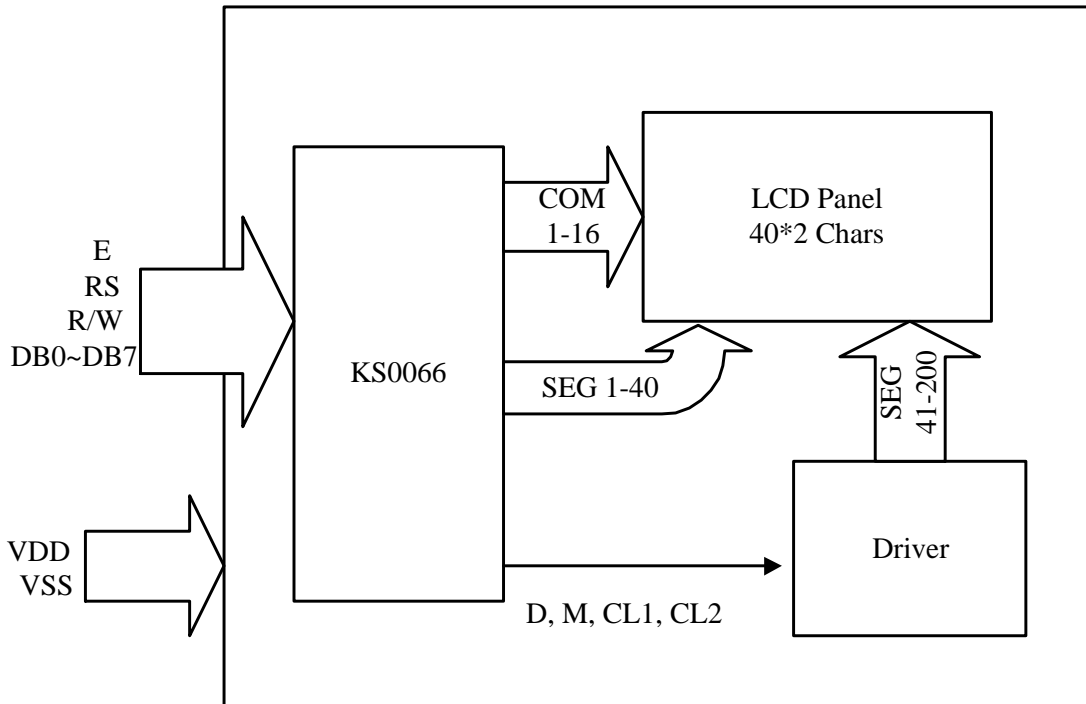

No.	Symbol	Function
1	VSS	Ground (0V)
2	VDD	Supply Voltage for Logic (+5V or +3.3V)
3	VO	Contrast Adjustment
4	RS	Data/Instruction Select
5	R/W	Read/Write Select
6	E	Enable Signal
7	DB0	Data Bus
8	DB1	Data Bus
9	DB2	Data Bus
10	DB3	Data Bus
11	DB4	Data Bus
12	DB5	Data Bus
13	DB6	Data Bus
14	DB7	Data Bus
15	LED_A	LED Power Supply + (5V)
16	LED_K	LED Power Supply - (5V)



## 7 POWER SUPPLY

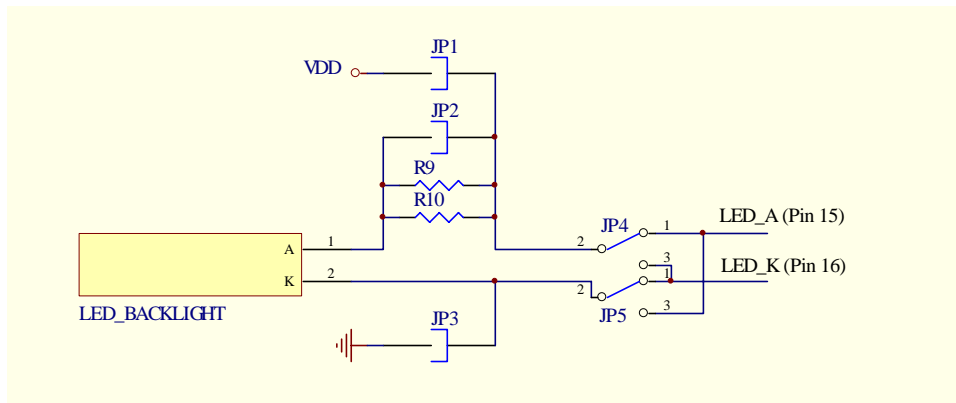
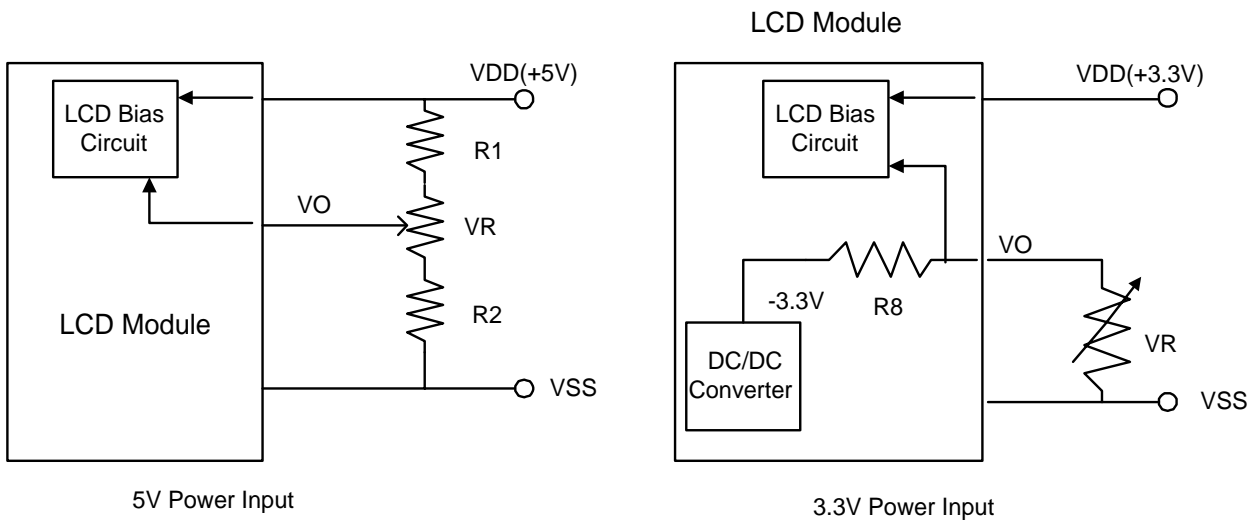

There are four methods to light up the LED back-light : (Please indicate while ordering.)

- (1) Built-in current-limit resistor(R9/R10). Add +5V between Pin15&16. (Default)
- (2) Add +4.05V between LED A & K directly.
- (3) Short JP2 and add +4.05V between Pin15&16.
- (4) Built-in current-limit resistor(R9/R10) and short JP1&JP3. Use the same power (+5V) with the logic circuit.

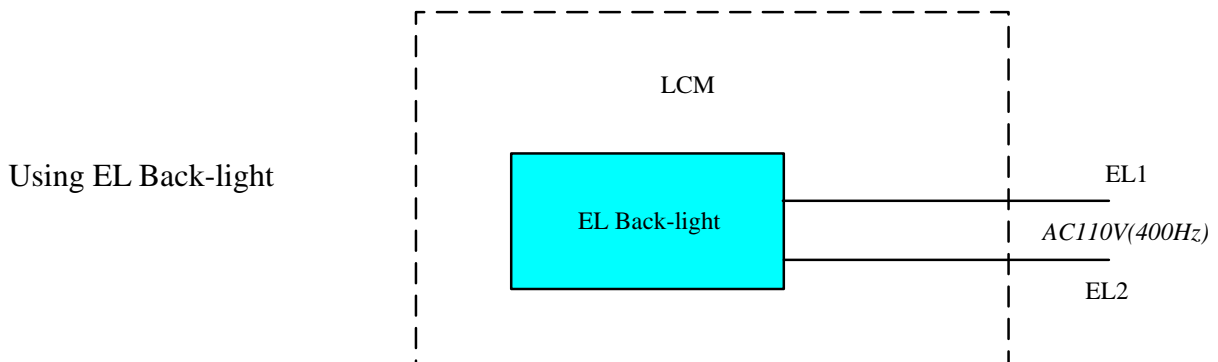

## 8 TIMING CHARACTERISTICS

### Write Operation

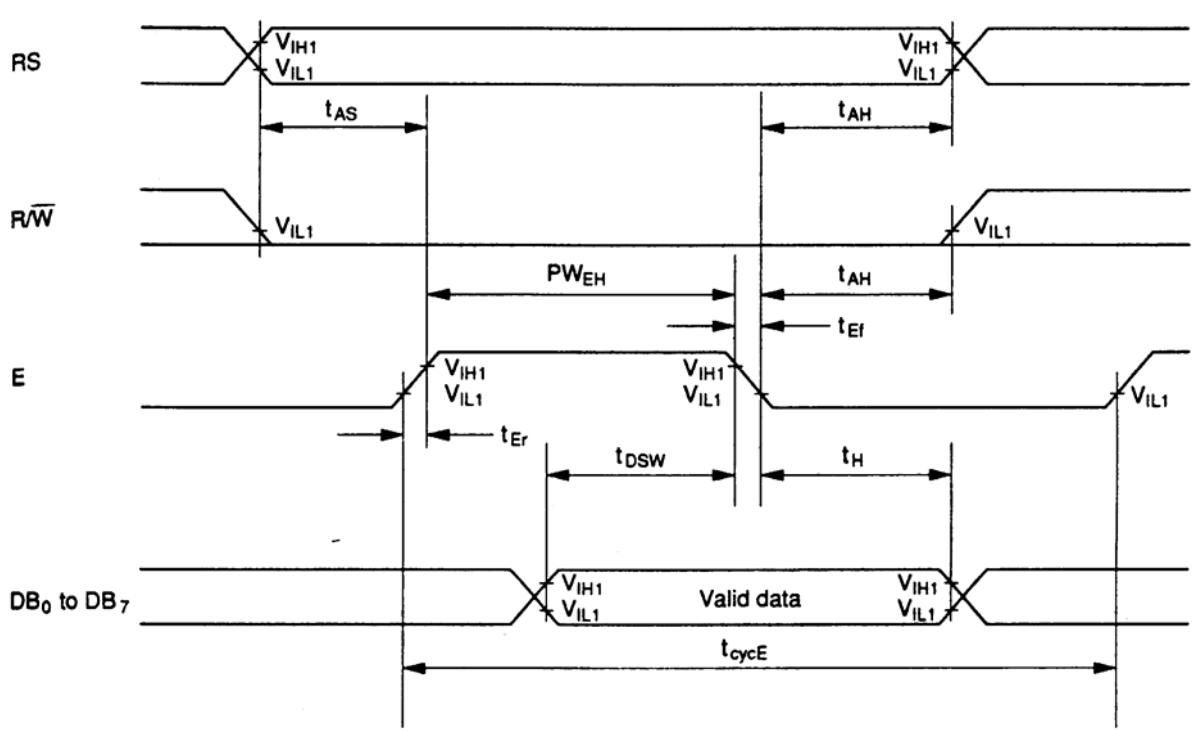

Item	Symbol	VDD=5V		VDD=3.3V		Unit
		Min	Max	Min	Max	
Enable cycle time	$t_{cycE}$	500	--	1000	--	ns
Enable pulse width	$PW_{EH}$	230	--	450	--	
Enable rise/fall time	$t_{Er}, t_{Ef}$	--	20	--	25	
Address set-up time (RS, R/W to E)	$t_{AS}$	40	--	60	--	
Address hold time	$t_{AH}$	10	--	20	--	
Data set-up time	$t_{DSW}$	80	--	195	--	
Data hold time	$t_H$	10	--	10	--	

## Read Operation

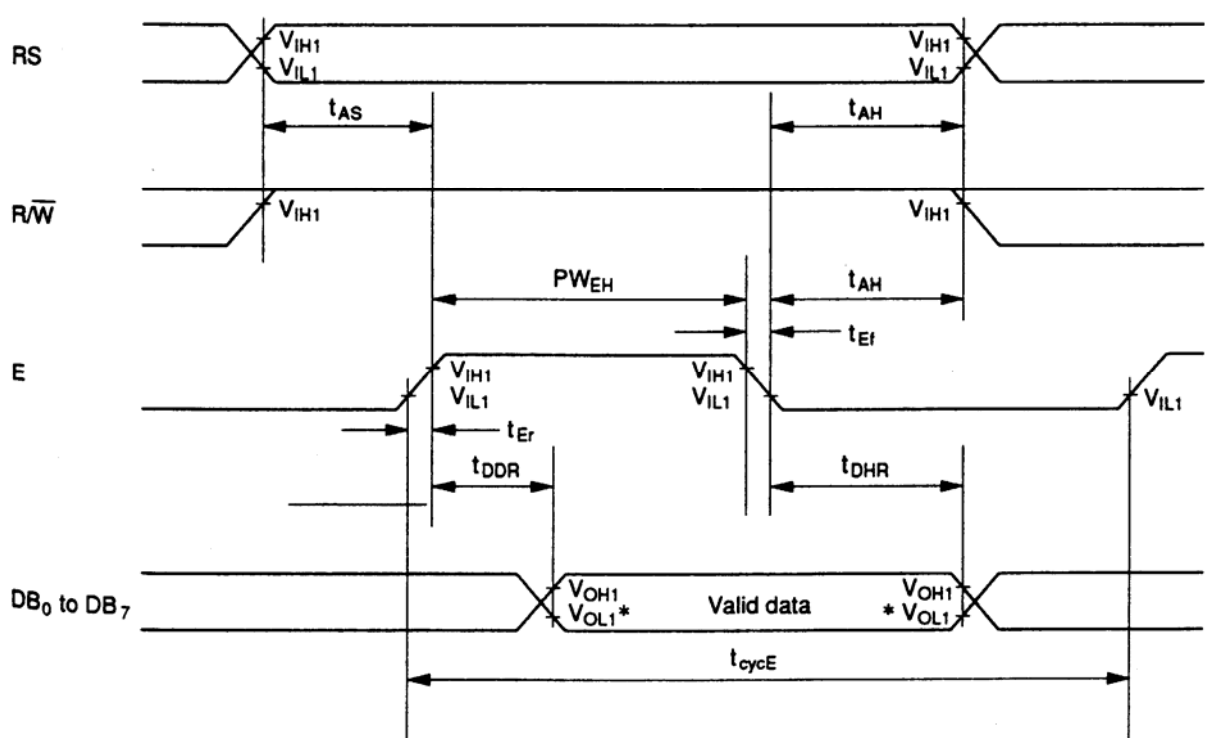

Item	Symbol	VDD=5V		VDD=3.3V		Unit
		Min	Max	Min	Max	
Enable cycle time	$t_{cycE}$	500	--	1000	--	ns
Enable pulse width	$PWEH$	230	--	450	--	
Enable rise/fall time	$t_{Er}, t_{Ef}$	--	20	--	25	
Address set-up time (RS, R/W to E)	$t_{AS}$	40	--	60	--	
Address hold time	$t_{AH}$	10	--	20	--	
Data delay time	$t_{DDR}$	--	120	--	360	
Data hold time	$t_{DRH}$	5	--	5	--	

## 9 INSTRUCTION SET

Instruction	Code										Description	E.T.(fosc =270 KHZ)
	RS	R/ W	D7	D6	D5	D4	D3	D2	D1	D0		
Clear Display	0	0	0	0	0	0	0	0	0	1	Write"20H" to DDRAM and set DDRAM address to "00H" from AC	1.53 ms
Return Home	0	0	0	0	0	0	0	0	1	--	Sets DD RAM address to "00H" from AC and return cursor to its original position if shifted. The contents of DDRAM are not changed.	1.53 ms
Entry Mode SET	0	0	0	0	0	0	0	1	I/D	SH	Assign cursor moving direction and enable the shift of entire display.	39 μS
Display ON/OFF Control	0	0	0	0	0	0	1	D	C	B	Set display (D), cursor (C), and blink of cursor (B) on/off control bit.	39 μS
Cursor or Display Shift	0	0	0	0	0	1	S/ C	R/ L	--	--	Set cursor moving and display shift control bit, and the direction, without changing of DDRAM data.	39 μS
Function Set	0	0	0	0	1	DL	N	F	--	--	Sets interface data length (DL:8-bit/4-bit), number of display lines (N:2-line/1-line) and , display font type (F:5x11dots/5x8 dost).	39 μS
Set CG RAM Address	0	0	0	1	AC 5	AC 4	AC 3	AC 2	AC 1	AC 0	Sets CG RAM address in address counter.	39 μS
Set DD RAM Address	0	0	1	AC 6	AC 5	AC 4	AC 3	AC 2	AC 1	AC 0	Sets DD RAM address in address counter.	39 μS
Read Busy Flag and Address	0	1	BF	AC 6	AC 5	AC 4	AC 3	AC 2	AC 1	AC 0	Whether during internal operation or not can be known by reading BF. The contents of address counter can also be read.	0 μS
Write Data to RAM	1	0	D7	D6	D5	D4	D3	D2	D1	D0	Writes data into internal RAM (DD RAM /CG RAM).	43 μS
Read Data from RAM	1	1	D7	D6	D5	D4	D3	D2	D1	D0	Reads data from internal RAM (DD RAM /CG RAM).	43 μS

\* "--" : don't care

Note : When an MPU program with checking the Busy Flag(DB7) is made, it must be necessary 1/2Fosc is necessary for executing the next instruction by the falling edge of the 'E' signal after the Busy Flag(DB7) goes to "LOW".

## 10 INITIALIZATION SEQUENCE

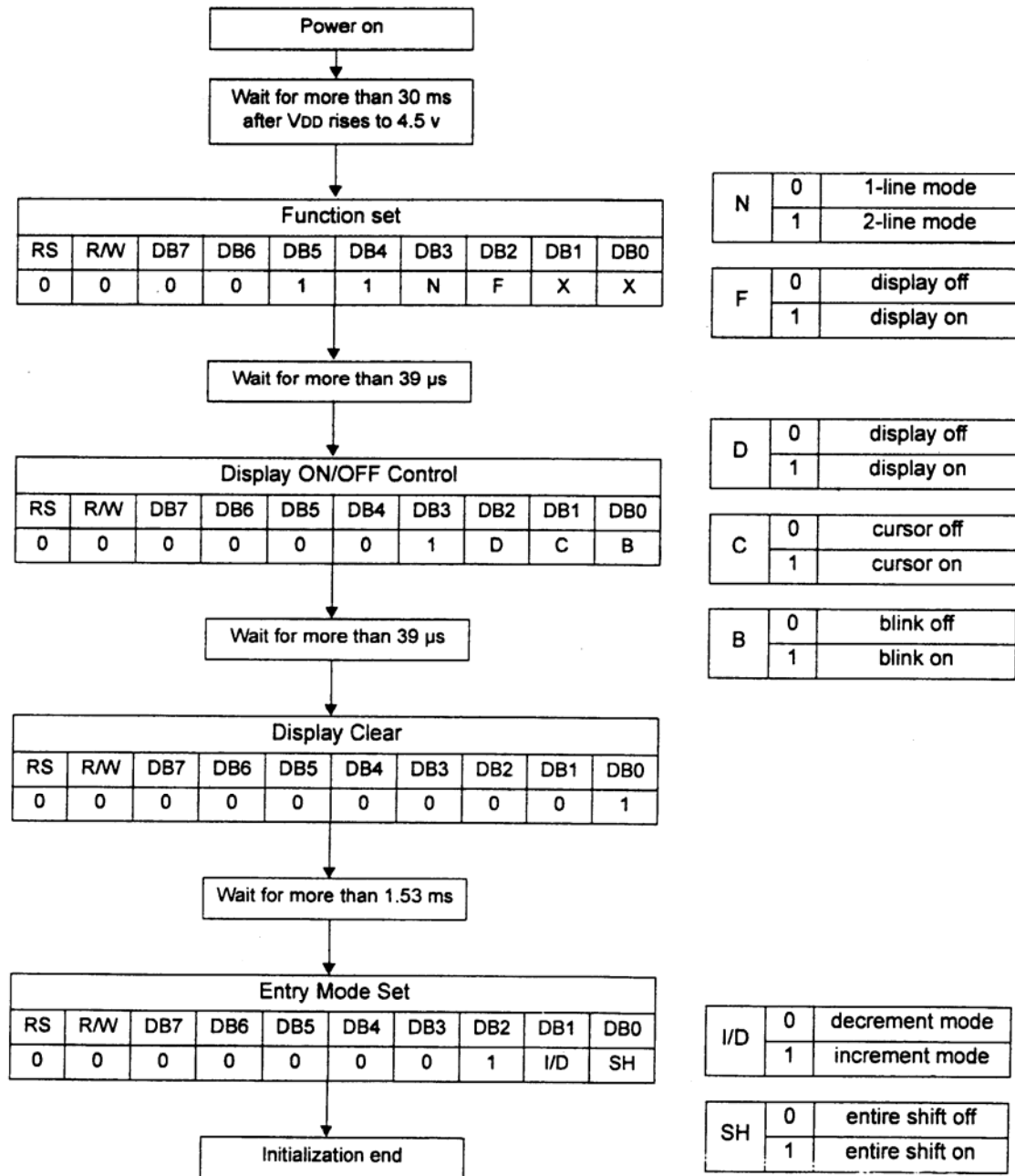

## 11 DD RAM ADDRESS

CHAR.	1	2	3	...	38	39	40
1 LINE	00	01	02	...	25	26	27
2 LINE	40	41	42	...	65	66	67

# 12 FONT TABLE

Upper 4bit Lower 4bit																	
	LLLL	LLLH	LLHL	LLHH	LHLH	LHLH	LHHL	LHHH	HLLL	HLLH	HLHL	HLHH	HHLH	HHLH	HHLH	HHHL	HHHH
LLLL	CG RAM (1)																
LLLH	(2)																
LLHL	(3)																
LLHH	(4)																
LHLH	(5)																
LHLH	(6)																
LHHL	(7)																
LHHH	(8)																
HLLL	(1)																
HLLH	(2)																
HLHL	(3)																
HLHH	(4)																
HHLH	(5)																
HHLH	(6)																
HHLH	(7)																
HHLH	(8)																

## **13 QUALITY AND RELIABILITY**

### **13.1 TEST CONDITIONS**

Tests should be conducted under the following conditions :

Ambient temperature :  $25 \pm 5^{\circ}\text{C}$

Humidity :  $60 \pm 25\% \text{ RH}$ .

### **13.2 SAMPLING PLAN**

Sampling method shall be in accordance with MIL-STD-105E , level II, normal single sampling plan .

### **13.3 ACCEPTABLE QUALITY LEVEL**

A major defect is defined as one that could cause failure to or materially reduce the usability of the unit for its intended purpose. A minor defect is one that does not materially reduce the usability of the unit for its intended purpose or is an infringement from established standards and has no significant bearing on its effective use or operation.

### **13.4 APPEARANCE**

An appearance test should be conducted by human sight at approximately 30 cm distance from the LCD module under fluorescent light. The inspection area of LCD panel shall be within the range of following limits.

### 13.5 INSPECTION QUALITY CRITERIA

Item	Description of defects			Class of Defects	Acceptable level (%)
Function	Short circuit or Pattern cut			Major	0.65
Dimension	Deviation from drawings			Major	1.5
Black spots	Ave . dia . D	area A	area B	Minor	2.5
	D≤0.2	Disregard			
	0.2<D≤0.3	3	4		
	0.3<D≤0.4	2	3		
	0.4<D	0	1		
Black lines	Width W, Length L	A	B	Minor	2.5
	W≤0.03	disregard			
	0.03<W≤0.05	3	4		
	0.05<W≤0.07 , L≤3.0	1	1		
	See line criteria				
Bubbles in polarizer	Average diameter D 0.2 < D < 0.5 mm for N = 4 , D > 0.5 for N = 1			Minor	2.5
Color uniformity	Rainbow color or newton ring.			Minor	2.5
Glass Scratches	Obvious visible damage.			Minor	2.5
Contrast ratio	See note 1			Minor	2.5
Response time	See note 2			Minor	2.5
Viewing angle	See note 3			Minor	2.5

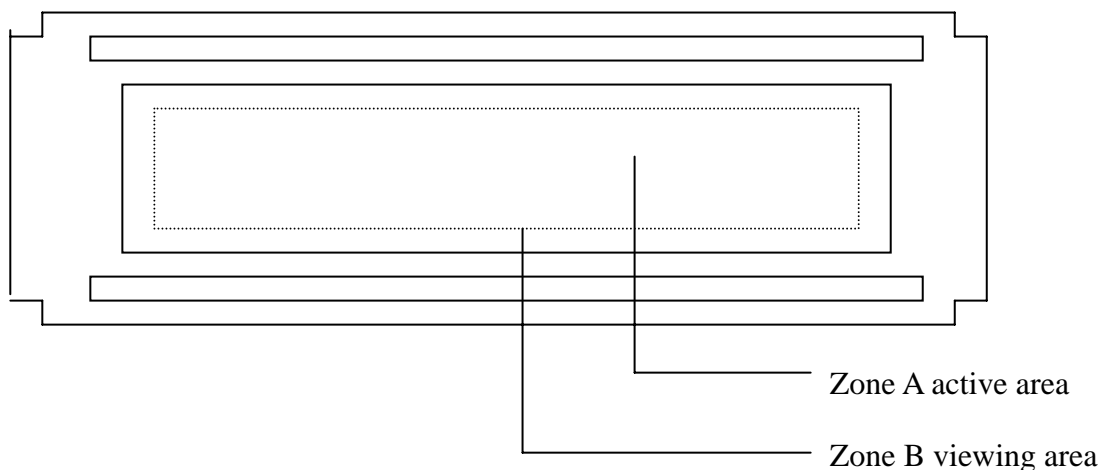



## 13.6 RELIABILITY

Test Item	Test Conditions		Note
	Normal Temp. type	Extended Temp. type	
High Temperature Operation	50±3°C , t=96 hrs	70±3°C , t=96 hrs	
Low Temperature Operation	0±3°C , t=96 hrs	-20±3°C , t=96 hrs	
High Temperature Storage	70±3°C , t=96 hrs	80±3°C , t=96 hrs	1,2
Low Temperature Storage	-20±3°C , t=96 hrs	-30±3°C , t=96 hrs	1,2
Temperature Cycle	-20°C ~ 25°C ~ 70°C 30 min. 5 min. 30 min. ( 1 cycle ) Total 5 cycle	-30°C ~ 25°C ~ 80°C 30 min. 5 min. 30 min. ( 1 cycle ) Total 5 cycle	1,2
Humidity Test	40 °C, Humidity 90%, 96 hrs		1,2
Vibration Test (Packing)	Sweep frequency : 10 ~ 55 ~ 10 Hz/1min Amplitude : 0.75mm Test direction : X.Y.Z/3 axis Duration : 30min/each axis		2

Note 1 : Condensation of water is not permitted on the module.

Note 2 : The module should be inspected after 1 hour storage in normal conditions  
(15-35°C , 45-65%RH).

Definitions of life end point :

- Current drain should be smaller than the specific value.
- Function of the module should be maintained.
- Appearance and display quality should not have degraded noticeably.
- Contrast ratio should be greater than 50% of the initial value.

## **14 HANDLING PRECAUTIONS**

- (1) A LCD module is a fragile item and should not be subjected to strong mechanical shocks.
- (2) Avoid applying pressure to the module surface. This will distort the glass and cause a change in color.
- (3) Under no circumstances should the position of the bezel tabs or their shape be modified.
- (4) Do not modify the display PCB in either shape or positioning of components.
- (5) Do not modify or move location of the zebra or heat seal connectors.
- (6) The device should only be soldered to during interfacing. Modification to other areas of the board should not be carried out.
- (7) In the event of LCD breakage and resultant leakage of fluid do not inhale, ingest or make contact with the skin. If contact is made rinse immediately.
- (8) When cleaning the module use a soft damp cloth with a mild solvent, such as Isopropyl or Ethyl alcohol. The use of water, ketone or aromatic is not permitted.
- (9) Prior to initial power up input signals should not be applied.
- (10) Protect the module against static electricity and observe appropriate anti-static precautions.

**15 OUTLINE DIMENSION**

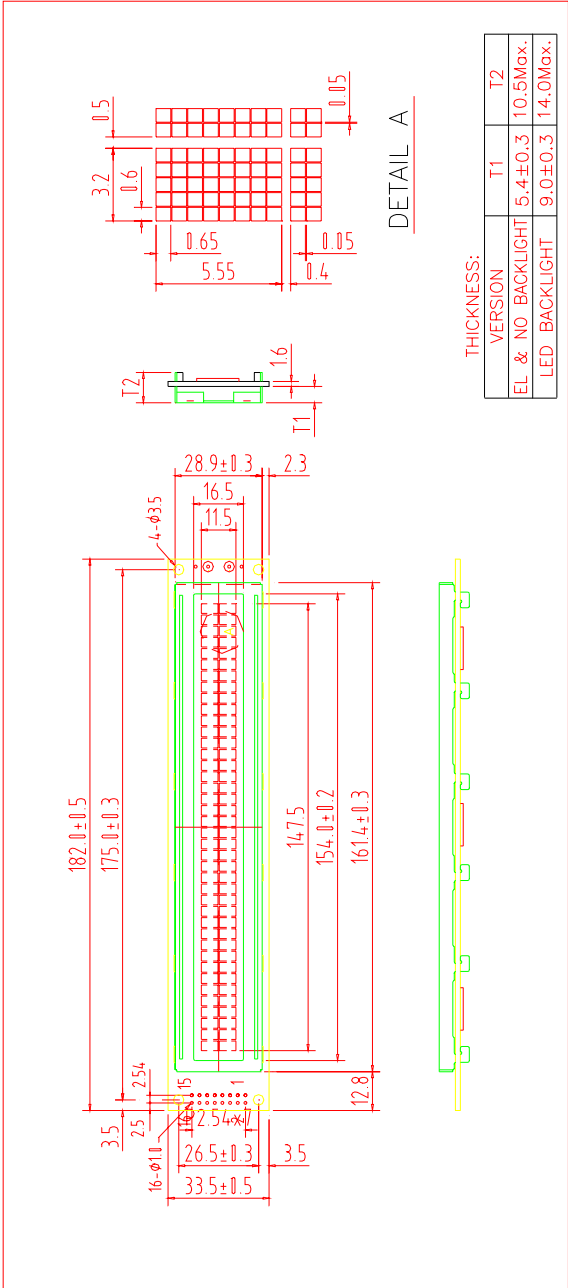

402A

THICKNESS:

VERSION	T1	T2
EL & NO BACKLIGHT	$5.4 \pm 0.3$	$10.5 \text{Max.}$
LED BACKLIGHT	$9.0 \pm 0.3$	$14.0 \text{Max.}$