



## SPECIFICATIONS FOR LCD MODULE

<b>CUSTOMER</b>	
<b>CUSTOMER PART NO.</b>	
<b>AMPIRE PART NO.</b>	<b>AG-12232A</b>
<b>APPROVED BY</b>	
<b>DATE</b>	

**AMPIRE CO., LTD.**

**TOWER A, 4F, No.114, Sec. 1, HSIN-TAI 5th RD., HIS-CHIH,  
TAIPEI HSIEN, TAIWAN(R.O.C.)**

**台北縣汐止鎮新台五路一段114號4樓(東方科學園區A棟)**

**TEL:886-2-26967269, FAX:886-2-26967196 or 886-2-26967270**

<b>APPROVED BY</b>	<b>CHECKED BY</b>	<b>ORGANIZED BY</b>

## RECORD OF REVISION

Revision Date	Page	Contents
1999/11/10	-	New Release
2000/10/6	12	Add power on / off sequence
	13	Modify sampling plan
2001/12/12		Modify LED characteristic
2007/2/7	7	Modify EL Back-light Characteristics

## 1 FEATURES

- (1) Display format : 122 × 32 dot-matrix ; 1/32 duty.
- (2) Construction : STN / FSTN LCD, Bezel, Zebra and PCB.
- (3) Optional LED or EL back-light.
- (4) Controller : SBN1661G.
- (5) Besides +5V for logic circuit, -5V is needed for LCD driving.
- (6) Normal / Extended temperature type.

## 2 NUMBERING SYSTEM

**AG-12232A** \_ \_ \_ \_ - \_  
                   **1 2 3 4 5**

No	Code Value	Description	Remark
1	G	STN gray type LCD	LCD Type
	Y	STN yellow green type LCD	
	S	STN negative type LCD	
	F	FSTN type LCD	
2	A	Reflective type / 6:00 view	Polarizer / Viewing Angel
	B	Reflective type / 12:00 view	
	I	Transflective type / 6:00 view	
	J	Transflective type / 12:00 view	
	T	Negative type / 6:00 view	
	U	Negative type / 12:00 view	
3	None	Without backlight	Backlight type
	L	5V LED	
	E	EL	
4	None	Without backlight	Backlight color
	Y	Yellow-green (LED)	
	B	Blue (EL)	
	W	White (EL)	
5	None	Normal temperature type	LCM temperature type
	H	Extended temperature type	

### 3 MECHANICAL DATA

Parameter	Stand Value	Unit
Dot size	0.40(W) × 0.45(H)	mm
Dot pitch	0.44(W) × 0.49(H)	mm
Viewing area	60.5(W) × 18.5(H)	mm
Module size	84.0(W) × 44.0(H) × 10.5 max (T)	mm
Module size ( LED back-light)	84.0(W) × 44.0(H) × 15.5 max (T)	mm

### 4 ABSOLUTE MAXIMUM RATINGS

Parameter		Symbol	Min	Max	Unit
Logic Circuit Supply Voltage		VDD-VSS	0	8.0	V
LCD Driving Voltage		VDD-VO	0	10.0	V
Input Voltage		VI	VSS	VDD	V
Normal temp. type	Operating Temp.	TOP	0	50	°C
	Storage Temp.	TSTG	-20	70	°C
Extended temp. type	Operating Temp.	TOP	-20	70	°C
	Storage Temp.	TSTG	-30	80	°C

## 5 ELECTRO-OPTICAL CHARACTERISTICS

Parameter	Symbol	Condition	Min	Typ	Max	Unit	Note
<b>----- Electronic Characteristics -----</b>							
Logic Circuit Supply Voltage	VDD-VSS	--	4.5	5.0	5.5	V	
LCD Driving Voltage (Normal Temp. type)	VDD-VO	0 °C	--	6.9	--	V	
		25 °C	--	6.4	--		
		50 °C	--	6.0	--		
LCD Driving Voltage(Extended Temp. type)	VDD-VO	-20 °C	--	9.4	--	V	
		0 °C	--	9.0	--		
		25 °C	--	8.6	--		
		50 °C	--	8.3	--		
		70 °C	--	8.0	--		
Input Voltage	VIH	--	0.7 VDD	--	VDD	V	
	VIL	--	VSS	--	0.3 VDD	V	
Logic Supply Current	IDD	VDD = 5V	--	1	2	mA	
<b>----- Optical Characteristics -----</b>							
Contrast	CR	STN type	--	5	--		Note 1
		FSTN type		7			
Rise Time	tr	25°C	--	100	150	ms	Note 2
Fall Time	tf	25°C	--	120	200	ms	
Viewing Angle Range	θ f	25°C & CR≥2	--	40	--	Deg.	Note 3
	θ b		--	35	--		
	θ l		--	40	--		
	θ r		--	40	--		
Frame Frequency	fF	25°C	--	60	--	Hz	

(NOTE 1) Contrast ratio :

$$CR = (\text{Brightness in OFF state}) / (\text{Brightness in ON state})$$

(NOTE 2) Response time :

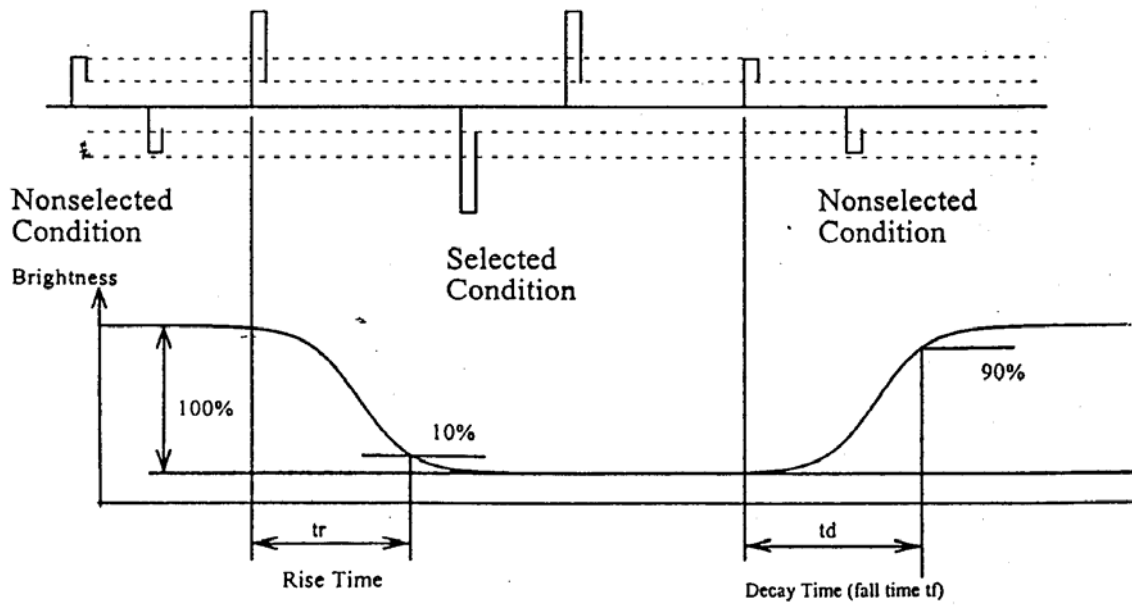

(NOTE 3) Viewing angle

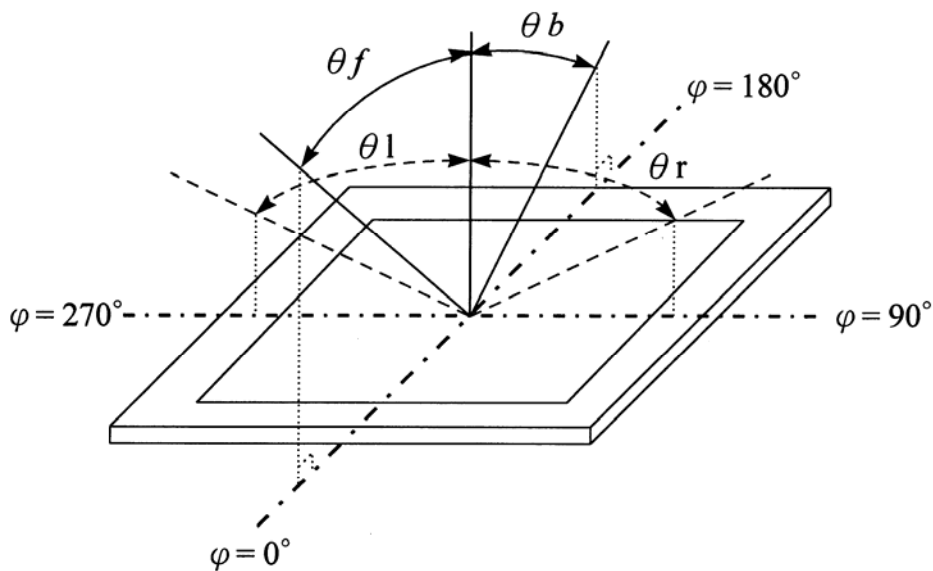

----- LED Back-light Characteristics -----							
Parameter	Symbol	Condition	Min	Typ	Max	Unit	Note
Forward Voltage	VF	--	--	4.05	4.3	V	Supply Voltage between A&K
Forward Current	IF	VF=4.05V	--	130	--	mA	
LCM Luminous intensity		VF=4.05V	--	30	--	cd/m <sup>2</sup>	

\* LED Dice number =  $2 \times 13 = 26$

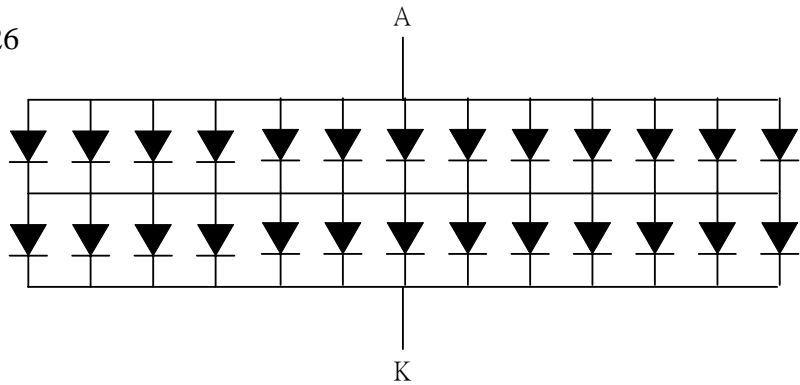

----- EL Back-light Characteristics -----		
Parameter	Specification	Unit
Color	Blue / White	-
Voltage	Vrms = 110	V(AC)
Frequency	Sine Wave = 400	Hz
Current Density	0.12	mA / cm <sup>2</sup>
LCM Initial Brightness	5	cd / m <sup>2</sup>

## 6 BLOCK DIAGRAM & INTERFACE

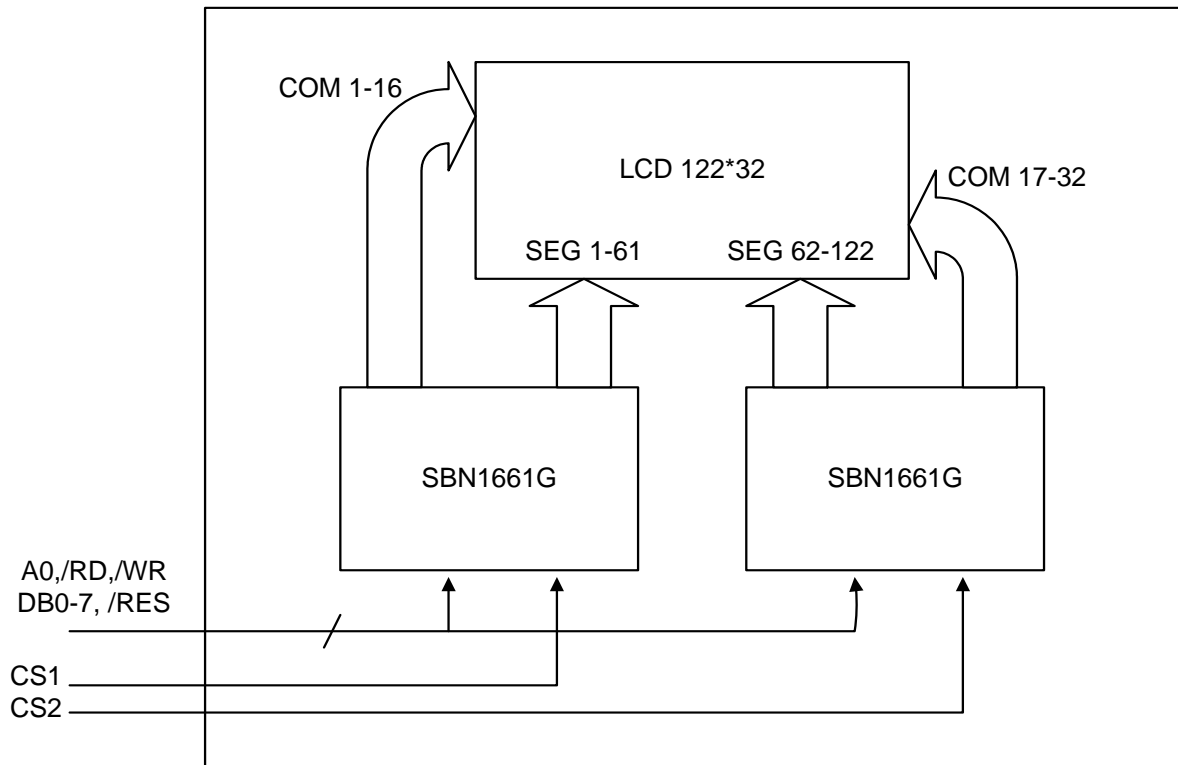

NO.	SYMBOL	FUNCTION
1	VSS	POWER SUPPLY (0V,GND)
2	VDD	POWER SUPPLY FOR LOGIC CIRCUIT
3	VO	POWER SUPPLY FOR LCD
4	A0	L→INSTRUCTION , H→ DATA
5	CS1	CHIP ENABLE ACTIVE "L"
6	CS2	CHIP ENABLE ACTIVE "L"
7	CL	EXTERNAL CLOCK (6~10KHZ)
8	/RD (E)	/RD FOR 80 SERIES, E FOR 68 SERIES
9	/WR(R/W)	/WR FOR 80 SERIES, R/W FOR 68 SERIES
10-17	DB0-DB7	DATA BUS LINE
18	RES	H→68 SERIES , L→80 SERES
19-20	LEDA,K	LED Supply Voltage (5V)



## 7 POWER SUPPLY

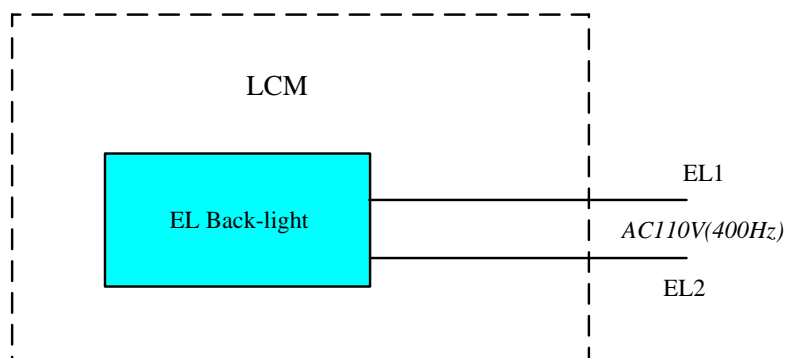
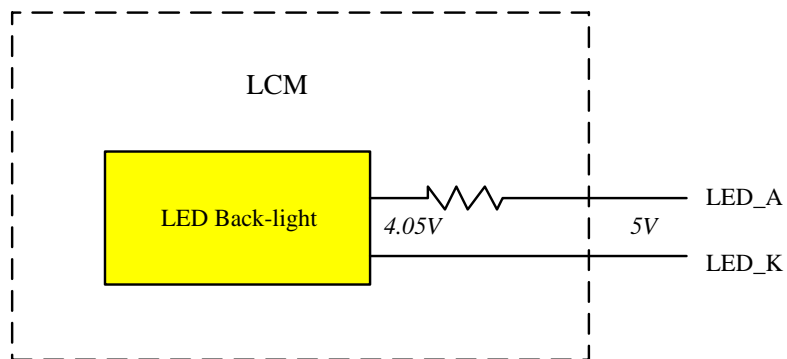
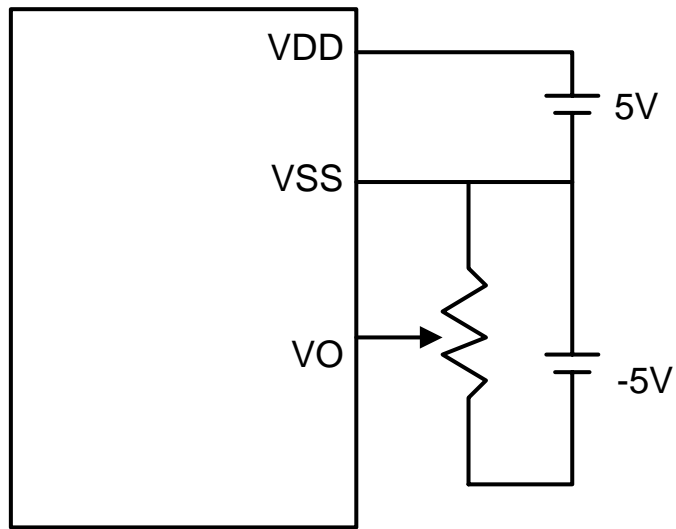

## 8 TIMING CHARACTERISTICS

### 8.1 Read / Write Time for 80-port MPU

ITEM	SYMBOL	CONDITION	MIN	MAX	UNIT
SYSTEM CYCLE TIME	tCYC8		1.0	--	us
CONTROL PULSE WIDTH	tCC		200	--	ns
ADDRESS SET-UP TIME	tAS		20	--	ns
ADDRESS HOLD TIME	tAH		10	--	ns
DATA SET-UP TIME	tDSW		80	--	ns
DATA HOLD TIME	tDH		10	--	ns
/RD ACCESS TIME	tACC	CL=100pH	--	90	ns
OUTPUT DISABLE TIME	tOH		10	60	ns

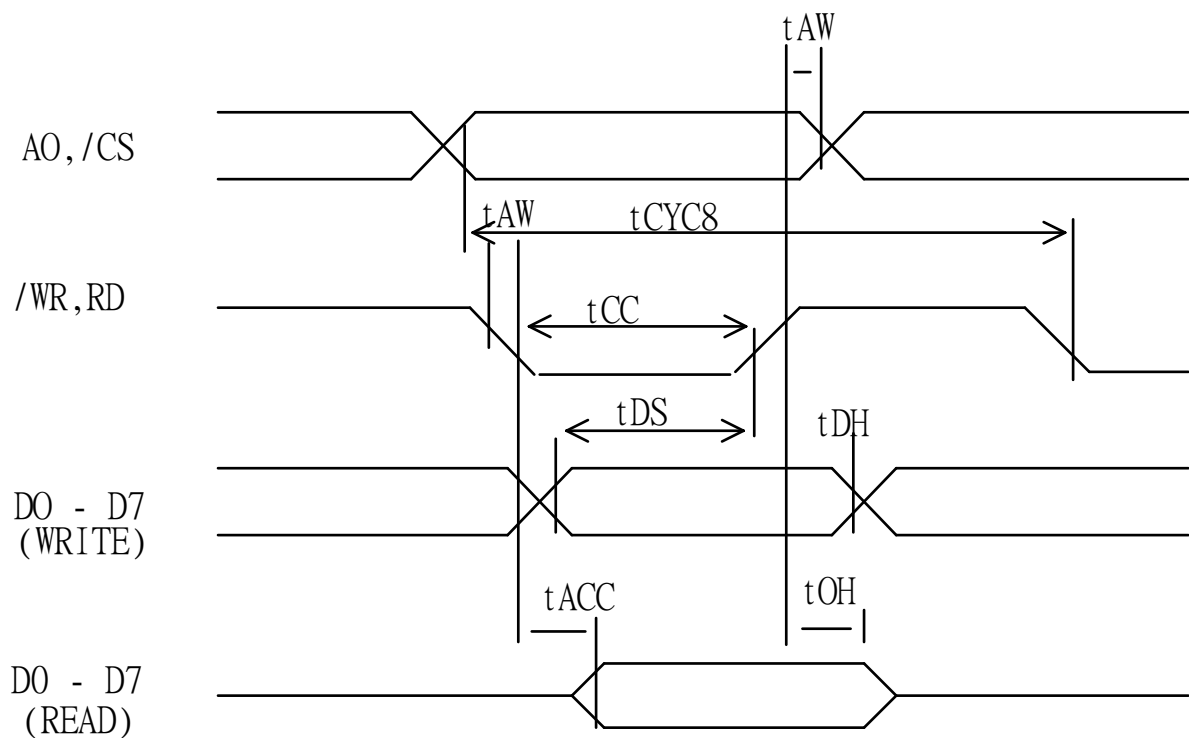

## 8.2 Read / Write Time for 68-port MPU

ITEM	SYMBOL	CONDITION	MIN	MAX	UNIT
SYSTEM CYCLE TIME	tCYC6		1.0	--	us
ADDRESS SET-UP TIME	tAS		20	--	ns
ADDRESS HOLD TIME	tAH		10	--	ns
DATA SET-UP TIME	tDD		80	--	ns
DATA HOLD TIME	tDH		10	--	ns
OUTPUT DISABLE TIME	tOH	CL=100pF	10	60	ns
ACCESS TIME	tACC		--	90	ns
ENABLE (READ)	tEW		100	--	ns
PULSE WIDTH (WRITE)		80	--		

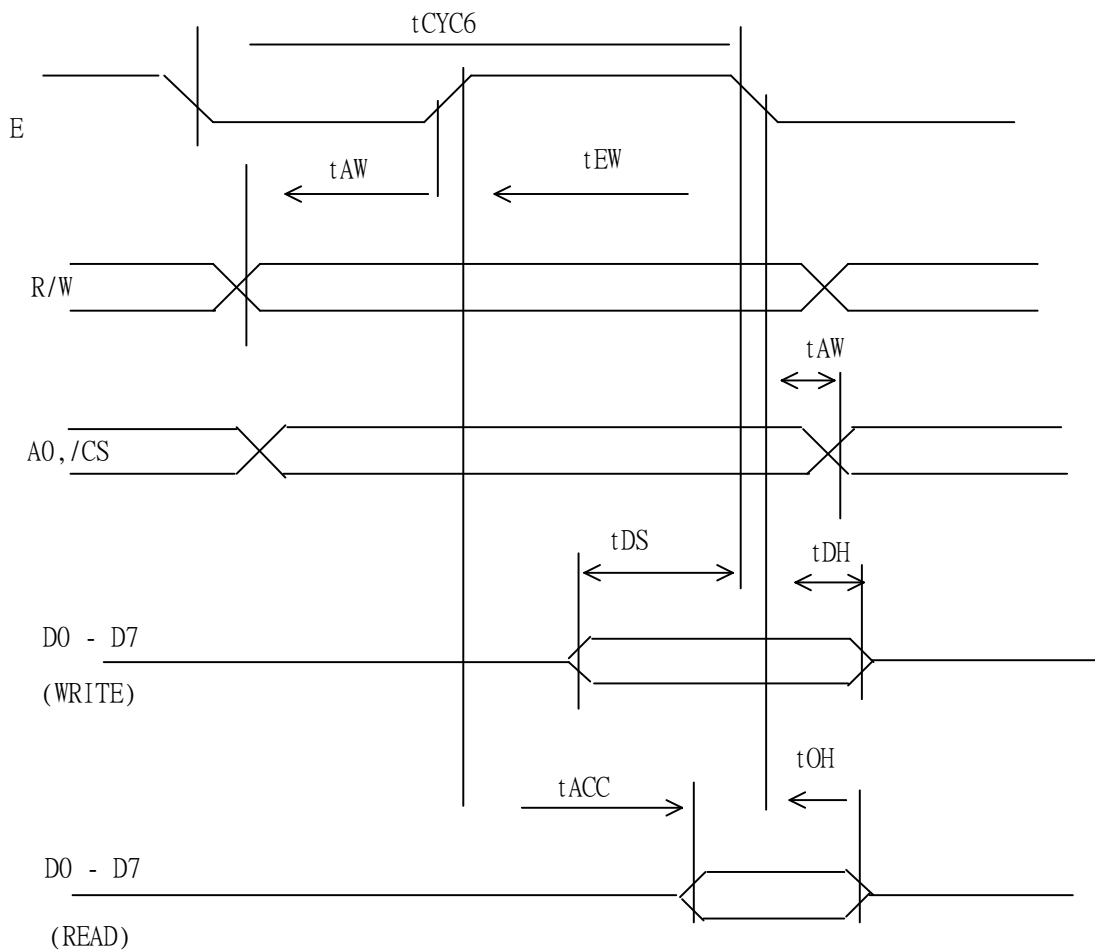

### 8.3 Power ON/OFF Sequence

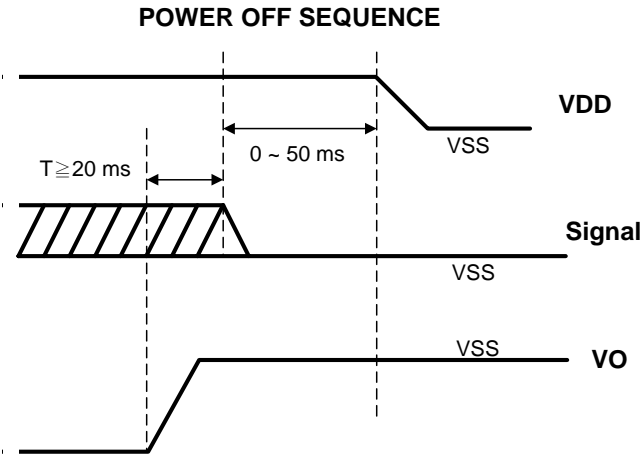
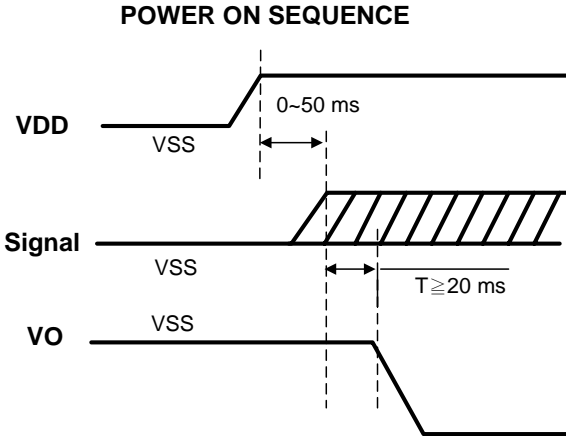

## **9 QUALITY AND RELIABILITY**

### **9.1 TEST CONDITIONS**

Tests should be conducted under the following conditions :

Ambient temperature :  $25 \pm 5^{\circ}\text{C}$

Humidity :  $60 \pm 25\% \text{ RH}$ .

### **9.2 SAMPLING PLAN**

Sampling method shall be in accordance with MIL-STD-105E , level II, normal single sampling plan .

### **9.3 ACCEPTABLE QUALITY LEVEL**

A major defect is defined as one that could cause failure to or materially reduce the usability of the unit for its intended purpose. A minor defect is one that does not materially reduce the usability of the unit for its intended purpose or is an infringement from established standards and has no significant bearing on its effective use or operation.

### **9.4 APPEARANCE**

An appearance test should be conducted by human sight at approximately 30 cm distance from the LCD module under fluorescent light. The inspection area of LCD panel shall be within the range of following limits.

## 9.5 INSPECTION QUALITY CRITERIA

Item	Description of defects			Class of Defects	Acceptable level (%)
Function	Short circuit or Pattern cut			Major	0.65
Dimension	Deviation from drawings			Major	1.5
Black spots	Ave . dia . D	area A	area B	Minor	2.5
	$D \leq 0.2$	Disregard			
	$0.2 < D \leq 0.3$	3	4		
	$0.3 < D \leq 0.4$	2	3		
	$0.4 < D$	0	1		
Black lines	Width W, Length L	A	B	Minor	2.5
	$W \leq 0.03$	disregard			
	$0.03 < W \leq 0.05$	3	4		
	$0.05 < W \leq 0.07, L \leq 3.0$	1	1		
	See line criteria				
Bubbles in polarizer	Average diameter D $0.2 < D < 0.5$ mm for N = 4 , D > 0.5 for N = 1			Minor	2.5
Color uniformity	Rainbow color or newton ring.			Minor	2.5
Glass Scratches	Obvious visible damage.			Minor	2.5
Contrast ratio	See note 1			Minor	2.5
Response time	See note 2			Minor	2.5
Viewing angle	See note 3			Minor	2.5

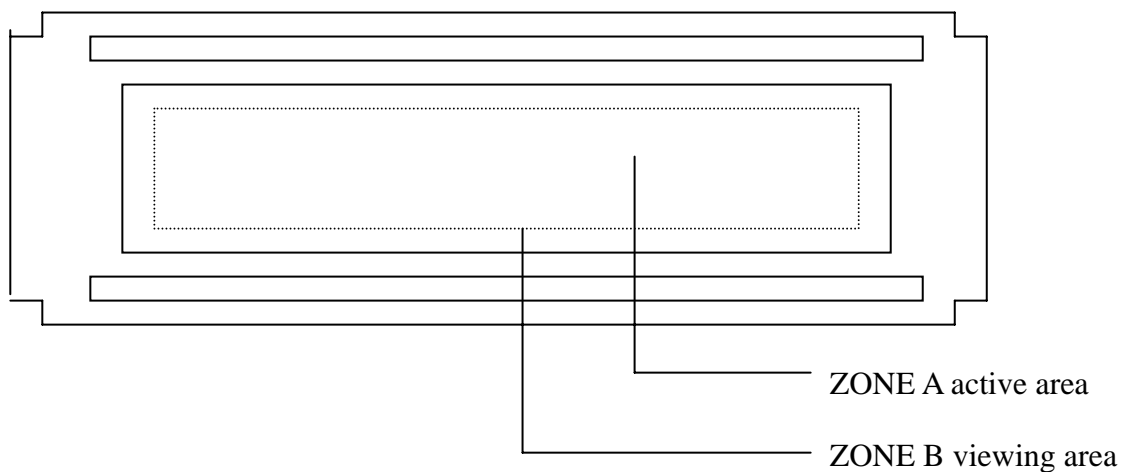

## 9.6 RELIABILITY

Test Item	Test Conditions		Note
	Normal Temp. type	Extended Temp. type	
High Temperature Operation	50±3°C , t=96 hrs	70±3°C , t=96 hrs	
Low Temperature Operation	0±3°C , t=96 hrs	-20±3°C , t=96 hrs	
High Temperature Storage	70±3°C , t=96 hrs	80±3°C , t=96 hrs	1,2
Low Temperature Storage	-20±3°C , t=96 hrs	-30±3°C , t=96 hrs	1,2
Temperature Cycle	-20°C ~ 25°C ~ 70°C 30 m in. 5 min. 30 min. ( 1 cycle ) Total 5 cycle	-30°C ~ 25°C ~ 80°C 30 min. 5 min. 30 min. ( 1 cycle ) Total 5 cycle	1,2
Humidity Test	40 °C, Humidity 90%, 96 hrs		1,2
Vibration Test (Packing)	Sweep frequency : 10 ~ 55 ~ 10 Hz/1min Amplitude : 0.75mm Test direction : X.Y.Z/3 axis Duration : 30min/each axis		2

Note 1 : Condensation of water is not permitted on the module.

Note 2 : The module should be inspected after 1 hour storage in normal conditions  
(15-35°C , 45-65%RH).

Definitions of life end point :

- Current drain should be smaller than the specific value.
- Function of the module should be maintained.
- Appearance and display quality should not have degraded noticeably.
- Contrast ratio should be greater than 50% of the initial value.

## **10 HANDLING PRECAUTIONS**

- (1) A LCD module is a fragile item and should not be subjected to strong mechanical shocks.
- (2) Avoid applying pressure to the module surface. This will distort the glass and cause a change in color.
- (3) Under no circumstances should the position of the bezel tabs or their shape be modified.
- (4) Do not modify the display PCB in either shape or positioning of components.
- (5) Do not modify or move location of the zebra or heat seal connectors.
- (6) The device should only be soldered to during interfacing. Modification to other areas of the board should not be carried out.
- (7) In the event of LCD breakage and resultant leakage of fluid do not inhale, ingest or make contact with the skin. If contact is made rinse immediately.
- (8) When cleaning the module use a soft damp cloth with a mild solvent, such as Isopropyl or Ethyl alcohol. The use of water, ketone or aromatic is not permitted.
- (9) Prior to initial power up input signals should not be applied.
- (10) Protect the module against static electricity and observe appropriate anti-static precautions.



# 11 OUTLINE DIMENSION

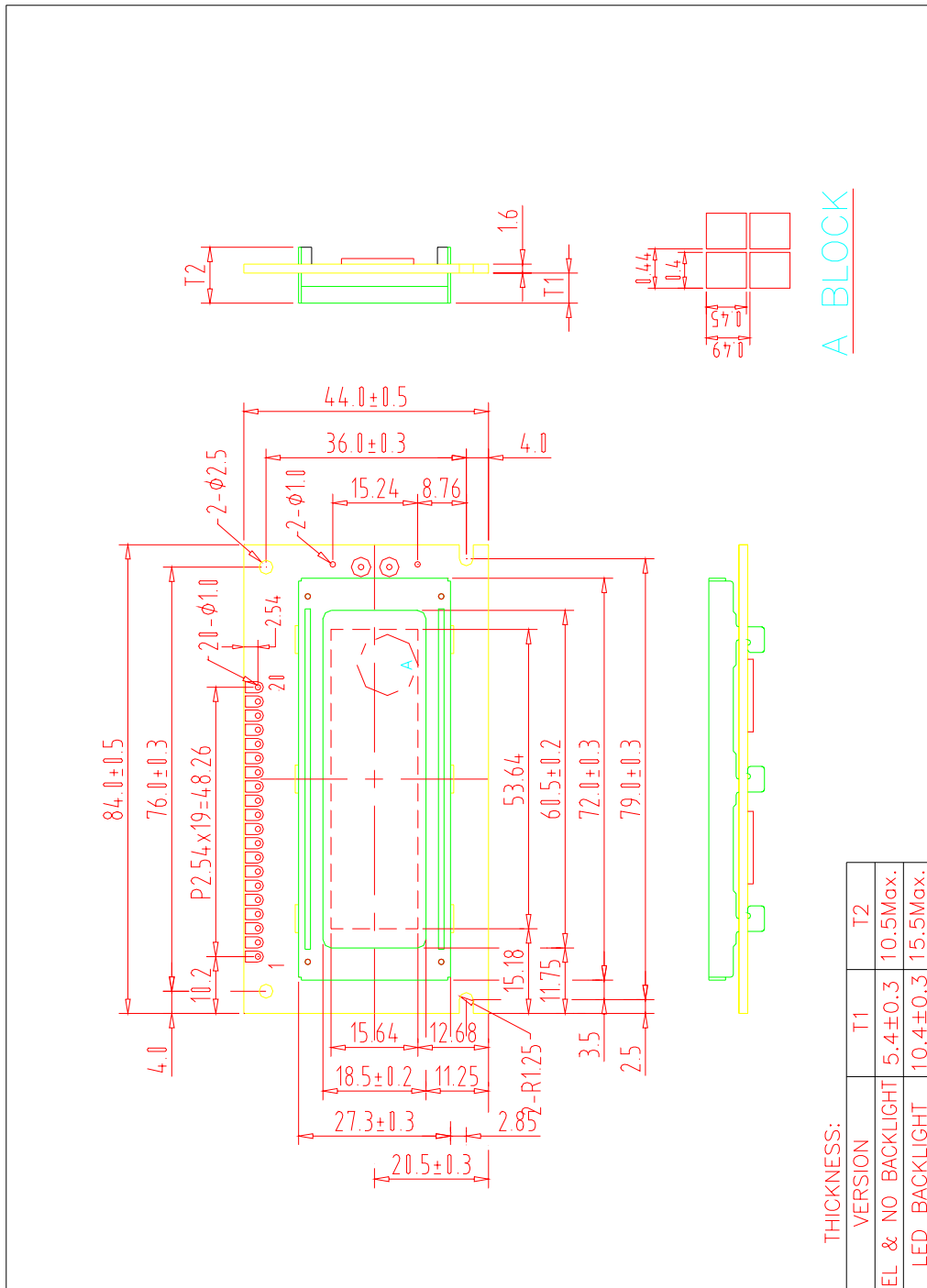

12232A

A BLOCK